

EPS-12000-CM EPS-12000-CM Managed Layer 2 or 3 Ethernet Switch Module



EPS-12000-CM without thermal solution



EPS-12000-CM with heat sink

FEATURES

12 Gigabit Ethernet ports with non-blocking wire-speed performance

RS-232 serial port provides out-of-band management interface

8K MAC addresses and 4K VLANs (IEEE 802.1Q), as well as 8K IPv4 and IPv6 multicast group support

Jumbo frame support at all speeds

Dual leaky bucket policers with remarking and statistics

Flexible link aggregation support based on Layer-2 through Layer-4 information (IEEE 802.3ad)

Multicast and broadcast storm control, as well as flooding control

Rapid Spanning Tree protocol (RSTP) and MSTP

8 priorities and 8 QoS queues per port with scheduling

Shaping/policing per queue and per port

Multiple protocol support: IEEE 802.1d, IEEE 802.1w, IEEE 802.1s, and IEEE 802.1X

Wide input voltage range: 7-34VDC

Latching connectors for improved ruggedness

COM Express Mini form factor: 84x55mm / 3.3x2.2"

Extremely rugged -40°C to +85°C operating temperature



EPS-12000-CMH with heat spreader

EPS-12000-CM is a managed Layer 2 or Layer 3 Ethernet switch module offering twelve 10/100/1000Mbps copper twisted pair ports in the ultra-compact COM Express Mini form factor. It is ideal for rugged applications including industrial, on-vehicle and military, where space is at a premium. The switch is based on Diamond's **EPSM-10GX** compact Ethernet switch module and uses a same-size carrier board to provide the power and magnetics circuitry to create a complete switch solution. This two-board design results in an ultra-compact size particularly suitable for UAVs and other unmanned vehicles.

All switch functions are managed by an embedded processor integrated into the switch. The processor is accessed via an in-band web interface over one of the Ethernet ports or via an out-of-band command-line interface over an RS-232 serial port. The integrated web interface provides an intuitive GUI for use in configuring and managing all switch functionality. On-board memory holds dual application images, boot code, MAC addresses, and other parameters, and can also be used for program execution.

EPS-12000-CM includes two innovative features that enable automatic power savings. The switch can detect unused Ethernet ports on network devices and power them down or place them in stand-by mode. Additionally, the switch actively adjusts the power level needed based on cable length, saving energy on links shorter than the 100m maximum specified length.

Input power is provided through the built-in, wide-range 6-34VDC power supply, enabling reliable operation with industrial power sources as well as vehicle power systems.

EPS-12000-CM was designed for use in vehicle and harsh environment applications. All I/O connectors are latching, providing enhanced reliability over the RJ-45 connectors used in commercial Ethernet switches. The -40°C to +85°C operating range makes it suitable for use in outdoor and vehicle applications.

EPS-12000-CM comes loaded with all required firmware, enabling its immediate operation without any development effort.

EPS-12000-CM comes with an integrated heat sink for cooling. An optional heat spreader is available for direct mounting to enclosure walls.

◆ Block Diagram

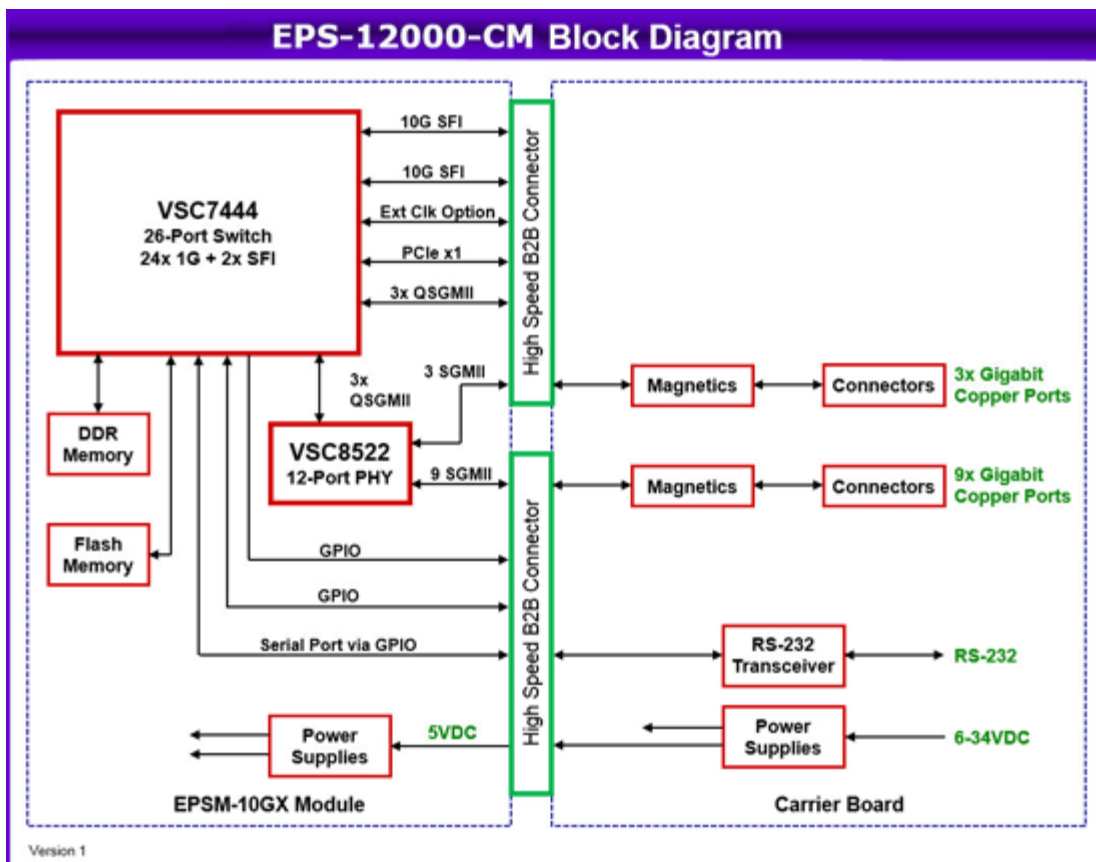

◆ **CK-EPS-12000-KIT: Cable kit for EPS-12000-CM**

Cable Kit for EPS-12000-CM: 3x Quad Gigabit Ethernet cables, Power cable, Serial cable



CK-EPS12000 includes the following cables:

No.	Qty	Cable	Description	Drawing
1	1	6981050	Serial Cable, 1x3 2mm to DB9M	Show
2	1	6981507	Power Cable, IPD 2x2 to Leads, 20AV	Show
3	3	6981508	Ethernet Cable, 4 Ports, JST 32 Pin	Show

Managed Ethernet Switch	
Switch Type	12 port Layer 2+ switch
Number of Ports	12 10/100/1000Mbps Ethernet ports with non-blocking wire-speed performance
On-board Memory	4Mb packet memory Shared memory buffer with per-port & CoS memory management
MEF	Hierarchical MEF compliant policing & scheduling MEF E-Lane, E-Line, and E-Tree services
Frame Buffer	Jumbo frame support at all speeds
VLAN	IEEE 802.1Q VLAN switch with 8K MACs and 4K VLANs Push/pop up to two VLAN tags Independent & shared VLAN learning (IVL, SVL)
Multicast	IPv4 and IPv6 multicast group support
Remarking	Dual leaky bucket policers with remarking and statistics
Classifier	8 priorities and 8 CoS queues per port with strict or deficit-weighted round robin scheduling Shaping/policing per queue and per port
Storm Control	Policing with storm control and MC/BC protection

Link Aggregation	IEEE 802.3ad
Security	Advanced security and prioritization available through multistage TCAM engine
RSTP	Rapid Spanning Tree Protocol (IEEE 802.1W) and MSTP
MIBs	Support for both WebStax and CEServices MIBs
Power Management	ActiPHY and PerfectReach power management VeriPHY cable diagnostics
Serial Port	1 RS-232 port for host interface
Standalone Capable	Standalone network switch, or in combination with a host computer
General	
Power Input	7 - 34VDC
Power Consumption	11W @12V i/p
Form Factor	COM Express Mini: 84 x 55mm / 3.3 x 2.2"
Operating Temperature	-40°C to +85°C (-40°F to +185°F)
Weight	TBD
RoHS	Compliant

◆ Models and Accessories

EPS-12000-CM		
available models:		
EPS-12000-CM	12 gigabit port Ethernet Switch, COM Express Mini, -40°C to 85°C; Webstax layer 2 software and heat sink	Available
EPS-12000-CM-1588	12 gigabit port Ethernet Switch, COM Express Mini, IStax layer 3 software and heat sink	Available
EPS-12000-CMH	12 gigabit port Ethernet Switch, COM Express Mini, -40°C to 85°C; Webstax layer 2 software and heat spreader	Available
EPS-12000-CMH-1588	12 gigabit port Ethernet Switch, COM Express Mini, IStax layer 3 software and heat spreader	Available

Please [login](#) or [signup](#) for an online quote request.

Cables and accessories	
available models:	
CK-EPS12000	Cable kit for EPS-12000-CM
6981050	Serial Cable, 1x3 2mm to DB9M
6981507	Power Cable, IPD 2x2 to Leads, 20AV
6981508	Ethernet Cable, 4 Ports, JST 32 Pin

Please [login](#) or [signup](#) for an online quote request.

www.diamondsystems.com | [Sunnyvale, California USA](#) | [+1-650-810-2500](tel:+16508102500) | sales@diamondsystems.com