

EPSM-12G2F 26-Port Miniature Rugged Managed Ethernet Switch Module

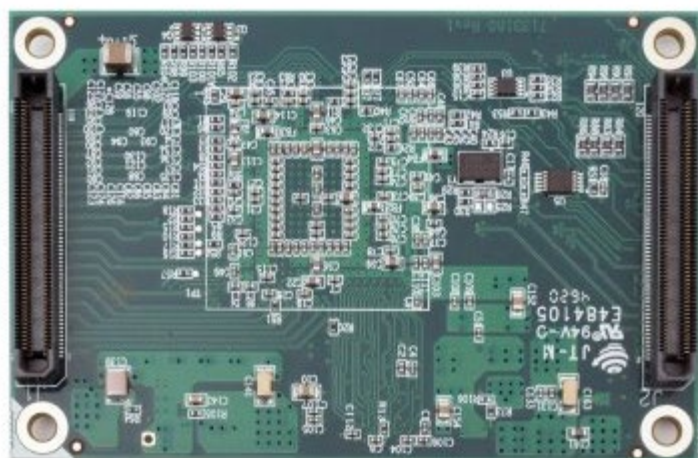

Top side view



Bottom side view

FEATURES

COM-like virtually-complete Ethernet switch with embedded software on a compact module

Enables rapid development of custom Ethernet switch boards and systems

Compact and economical solution for applications requiring managed switching capability

Only magnetics, connectors, and input voltage regulator needed to create complete solution

Design kit available with carrier board schematics and bill of materials

24 1G copper Ethernet ports: 12 from on-board PHY, 12 from carrier board PHY

2 1G / 2.5G ports for SFP or rugged optical transceivers

Layer 2+ managed Ethernet switch software built-in

High speed connectors carry all signals to carrier board

Only 55 x 84mm / 2.2 x 3.3", same size as a business card

-40 to +85°C operating temperature supports rugged mobile applications

Heat sink and heat spreader thermal solutions and design files available

Custom carrier board design and manufacturing services available

◆ Description

EPSM-12G2F is a managed Ethernet switch module in an ultra-compact 2.2" x 3.3" (55 x 84mm) size offering 24 10/100/1000Mbps copper ports and 2 1-2.5Gbps SFP ports. It supports an embedded software package offering a full suite of Layer 2 managed Ethernet switching capabilities. The module is intended to be used on a carrier board to implement a complete Ethernet switching solution. The core Ethernet switching technology is almost fully encapsulated on the module; for many applications, only the "last inch" of magnetics and I/O connectors is required to complete the circuit, enabling easy development of custom form factor compact, rugged Ethernet switch solutions.

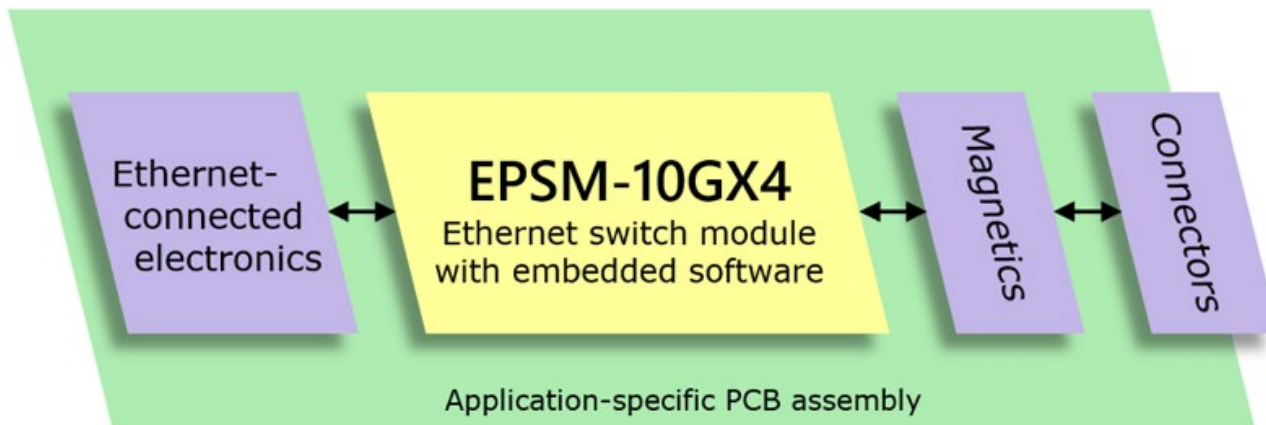

EPSM-12G2F offers compelling advantages over in-house designed Ethernet switches requiring mid-range software features:

- Small size fits into robots, drones, and other applications where size and weight are critical
- Rugged design and wide temperature capability are ideal for vehicle applications where high levels of shock and vibration are present
- Off the shelf solution significantly reduces development time and risk
- Built-in embedded software provides the most popular managed switch features, all configurable via web or serial port interfaces, eliminating the need for any software development

◆ Block Diagram

The block diagram below shows the EPSM-12G2F module in a typical application.

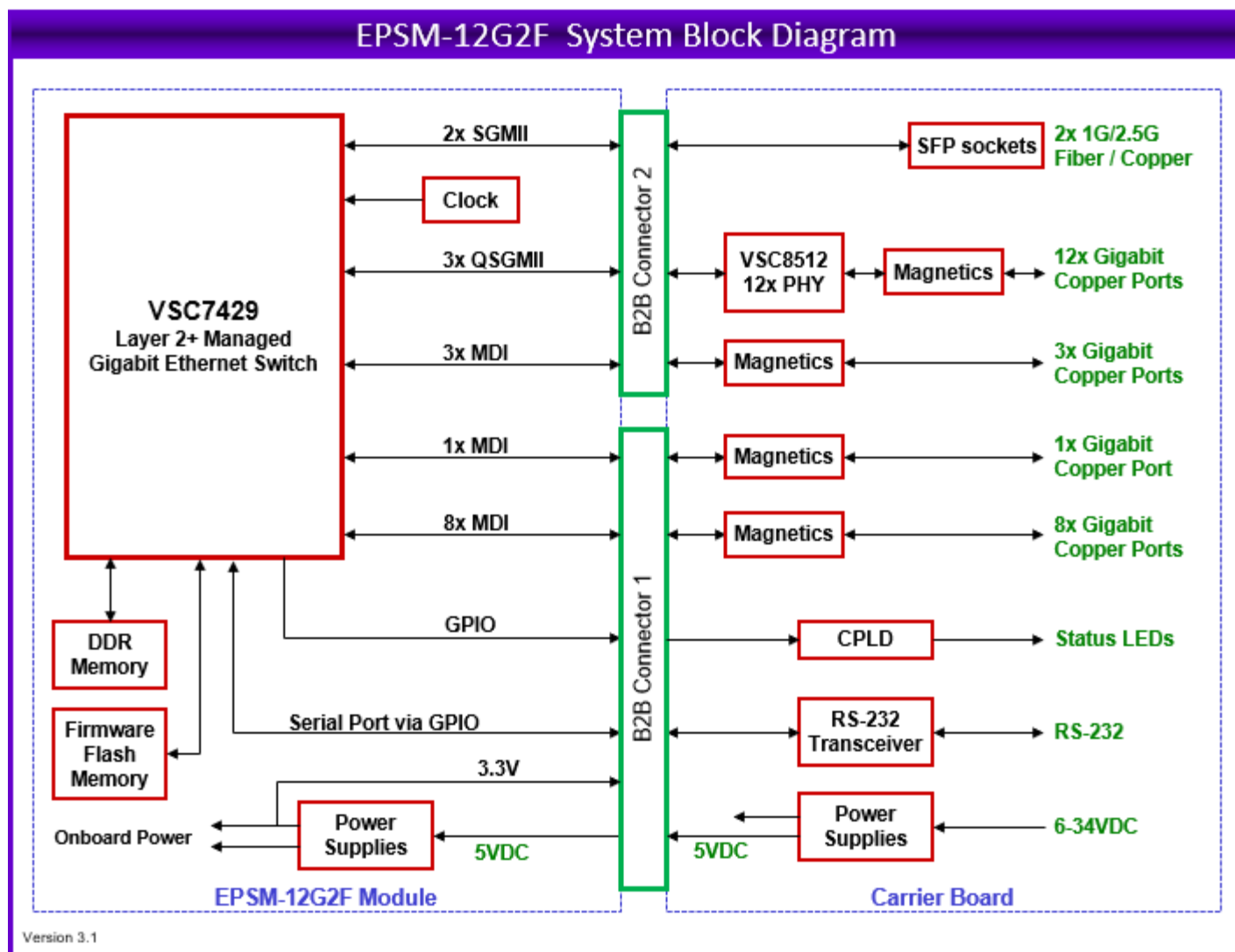

◆ Embedded Software

EPSM-12G2F includes the feature-rich WebStaX Layer 2 managed Ethernet switch software. The table below shows some of the more popular features included. For a complete list of features, [click here](#).

8K MAC addresses and 4K VLANs (IEEE 802.1Q)

8K IPv4 and IPv6 multicast group support

Jumbo frame support at all speeds

Flexible link aggregation support based on Layer-2 through Layer-4 information (IEEE 802.3ad)

Multicast and broadcast storm control, as well as flooding control

Rapid Spanning Tree protocol (RSTP) and MSTP

Multiple protocol support: IEEE 802.1d, IEEE 802.1w, IEEE 802.1s, and IEEE 802.1X

8 priorities and 8 QoS queues per port with scheduling

DIAMOND SYSTEMS
EPDM-12G2F™ Gigabit Ethernet Switch
 Software version w3.67-v1.0.0

Port State Overview

The port states are illustrated as follows:

| RJ45 | State | Icon |
|----------|----------|--------------|
| Disabled | Disabled | Grey square |
| Down | Down | Black square |
| Link | Link | Green square |

◆ Cooling Options

Two cooling accessory options are available: A heat sink provides convection cooling in a low profile, while a heat spreader provides improved conduction cooling for superior high temperature performance in applications where physical contact with the system enclosure is available.



◆ Development Support

A design guide is available with circuit details and other technical information necessary to design a carrier board around the EPDM-12G2F. A development kit is also available including:

- A technical design package (schematics, PCB layout, and Bill of Materials) of our EPS-24G4X carrier board, featuring support for 12 1G ports from the module, PHY for 12 additional 1G ports, dual SFP sockets, LED control logic, and power supply circuit
- CPLD code for status LED control logic
- A complete EPS-24G4X switch with the EPDM-12G2F module installed
- A cable kit
- Free custom branding of the embedded software (logo / color / title only; custom configurations are

extra charge)

Contact Diamond Systems for further information and ordering instructions.



◆ Custom Carrier Board Design

Diamond Systems engages in the design and manufacturing of custom carrier boards for our Ethernet switch modules. Contact us to learn more about how we can provide a cost-effective, low-risk, quick time to market solution for your Ethernet switch project using the EPSM-12G2F switch module and a custom carrier board that fits your exact needs.

◆ Specifications

| | |
|--------------------|--|
| Number of Ports | 2 1G/2.5G SFP ports for fiber or copper connection |
| Implementation | Magnetics and SFP sockets required on carrier board |
| On-board Memory | 4MB packet memory |
| Network Management | SNMP v1/v2c/v3; Web GUI and command line interface (CLI) |
| Power Management | ActiPHY and PerfectReach power management reduce power for shorter cable lengths and shut down power to disconnected ports |
| Serial Port | 1 serial port for host interface; RS-232 transceiver required on carrier board |
| Indicator lights | Serial data stream provided for 2 LEDs per port; decoder logic required on carrier board |
| Form Factor | 55x84mm / 2.17x3.31" (Same as COM Express Type 10) |
| Interconnect | Dual Samtec ERF5 series connectors, 120 pins each, 10mm board to board spacing |
| Input voltage | 5VDC +/-5% |

| | |
|-----------------------|--|
| Power consumption | 8.0W (24VDC input, 12 ports active) |
| Operating temperature | -40 to +85°C with DSC-provided heat sink or heat spreader |
| Cooling | Heat sink, 55x84mm, 16.6mm height Heat spreader, 55x104mm, 7.6mm height |
| Weight | 85G / 3.0 oz |
| Rohs | Compliant |

◆ Models and Accessories

EPSM-12G2F

available models:

EPSM-12G2F 26-port gigabit Ethernet switch module with Layer 2+ embedded software Available

Please [login](#) or [signup](#) for an online quote request.

www.diamondsystems.com | [Sunnyvale, California USA](#) | [+1-650-810-2500](tel:+16508102500) | sales@diamondsystems.com