

R15L600-65A1FTP

15" IP65 Stainless PCAP Chassis Display



KEY FEATURES

- IP65 compliant
- Robust and fanless design for reliable operation
- Fanless Cooling System and Ultra Low power consumption
- SUS 316/ AISI 316 stainless steel for food and chemical industries
- Special Flat Touch Design easy to maintain
- Projective Capacitive Touch
- Optical bonding (optional)



SPECIFICATIONS

Display	
Resolution	1024x768
Contrast Ratio	2500:1
Display Color	16.7M Colors
Active Area	304.1x228.1 mm
Size	15.0 inches
Panel Brightness	500.0 nits
View Angles	88,88,88,88
Touch / Glass	Projected Capacitive Multi Touch Screen
Mechanical	
Dimension	396 x 310 x 49 mm
Mounting	VESA Mount
Cooling System	Fanless design
Weight	5.7 kg
Enclosure	Stainless Housing
Environment	
Operating Humidity	10% to 90% RH, Non-Condensing
Storage Temperature	-20°C to 60°C
Operating Temperature	0°C to 45°C
IP rating	IP65
Certification	
Certification	CE, FCC
IO Ports	
Power Input	1 x M12 waterproof connector for 12V DC
Serial Port	1 x M12 type connector for RS232 remote control (Optional)
Indicator	1 x LED Indicator for power 1 x LED Indicator for status
USB Port	1x M12 waterproof connector for touch screen control
Video	1x M12 type connector for VGA input
Control	
Button	1 x Power Button 1 x Adjust up button 1 x Adjust down button 1 x ESC (Auto) button 1 x OK (Menu) button
Accessory	
Accessory	External VGA cable with waterproof connector Waterproof caps VESA screws 100~240V AC to DC Adapter with waterproof
Optional Accessory	External COM cable with waterproof connector for remote control (Optional)

connector
Power Cord

Power

Power Rating 12V DC (M12 type)

DIMENSIONS UNIT:MM

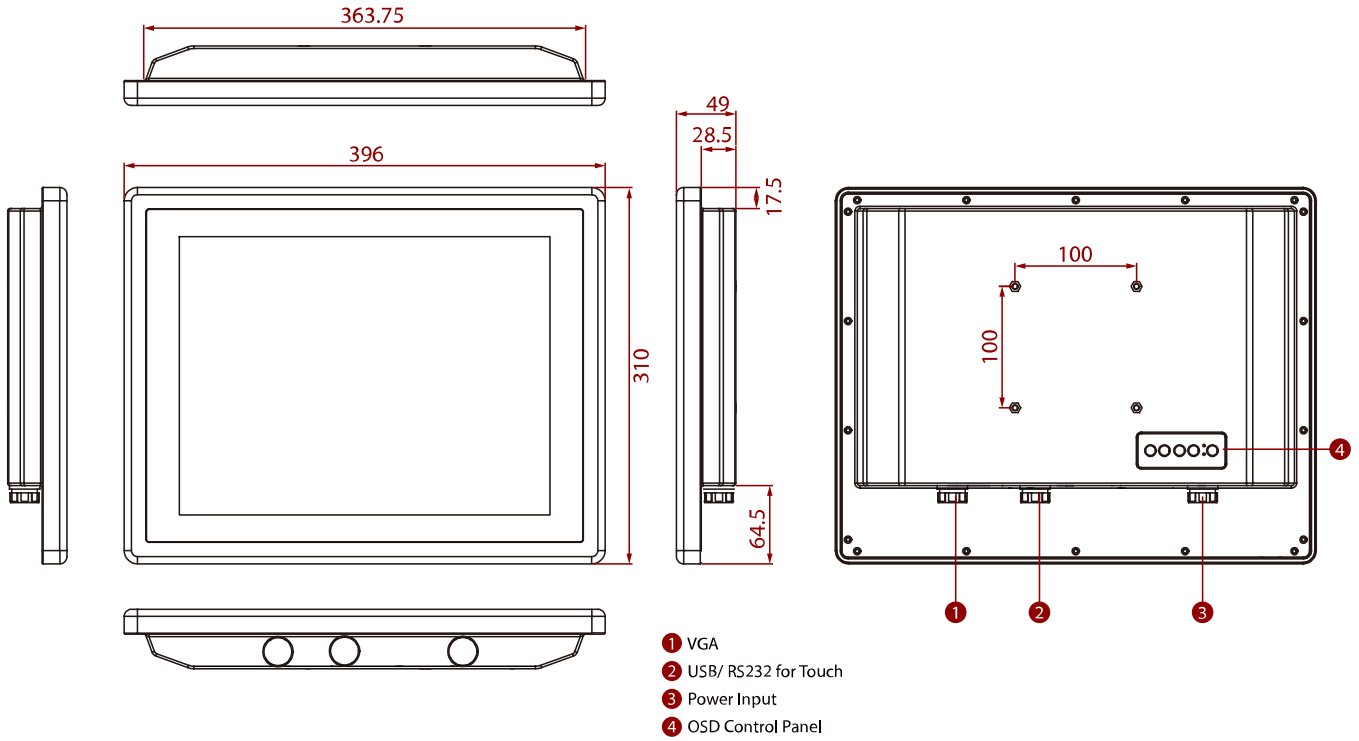

NOTE

1. This is a simplified drawing and some components are not marked in detail.
2. Please contact our sales representative if you need further product information.
3. All specifications are subject to change without prior notice.
4. The product shown in this datasheet is a standard model. For diagrams that contain customized or optional I/O, please contact the Winmate Sales Team for more information.