

TPM-3515RW

Arestech

15.6" Full HD Aluminum bezel IP65 Protected Industrial Monitor with Resistive Touchscreen



Features

- 15.6" LCD Panel 1920x1080 (FHD) / 1366x768 (HD) Resolution
- IP 65 aluminum front cover protection
- Resistive touch Screen Support
- Display Port/ HDMI / VGA
- DC 12-24V Power input

Applications

- Industrial HMI Display Systems
- ATM / Self-service / Kiosk Applications
- Vending / Ticketing Machines
- Point-of-information Terminals
- Factory / Machine Automation

→ Packing List

Description
1 x TPM-3515RW
1 x USB Cable
1 x VGA Cable
1 x Power Adapter
10 x Panel Mount Screws

→ Optional Items

Part No.	Description
ACS-PS-US	Power Cable 3-pin, 180 cm, USA Type
ACS-PS-EU	Power Cable 3-pin, 180 cm, Euro Type
ACS-PS-CN	Power Cable 3-pin, 180 cm, China Type
ACS-100-STD	VESA Table Stand

→ Ordering Information

Part No.	Description
TPM-3515RW-1A2	15.6" 16:9 LCD (1366 x 768), 300 nits, Aluminum IP65 front panel, Resistive Touch Screen USB interface, VGA/DP/HDMI, 12~24V DC input, Phoenix Connector
TPM-3515RW-2A2	15.6" 16:9 LCD (1920 x 1080), 450 nits, Aluminum IP65 front panel, Resistive Touch Screen USB interface, VGA/DP/HDMI, 12~24V DC input, Phoenix Connector

→ Dimensions

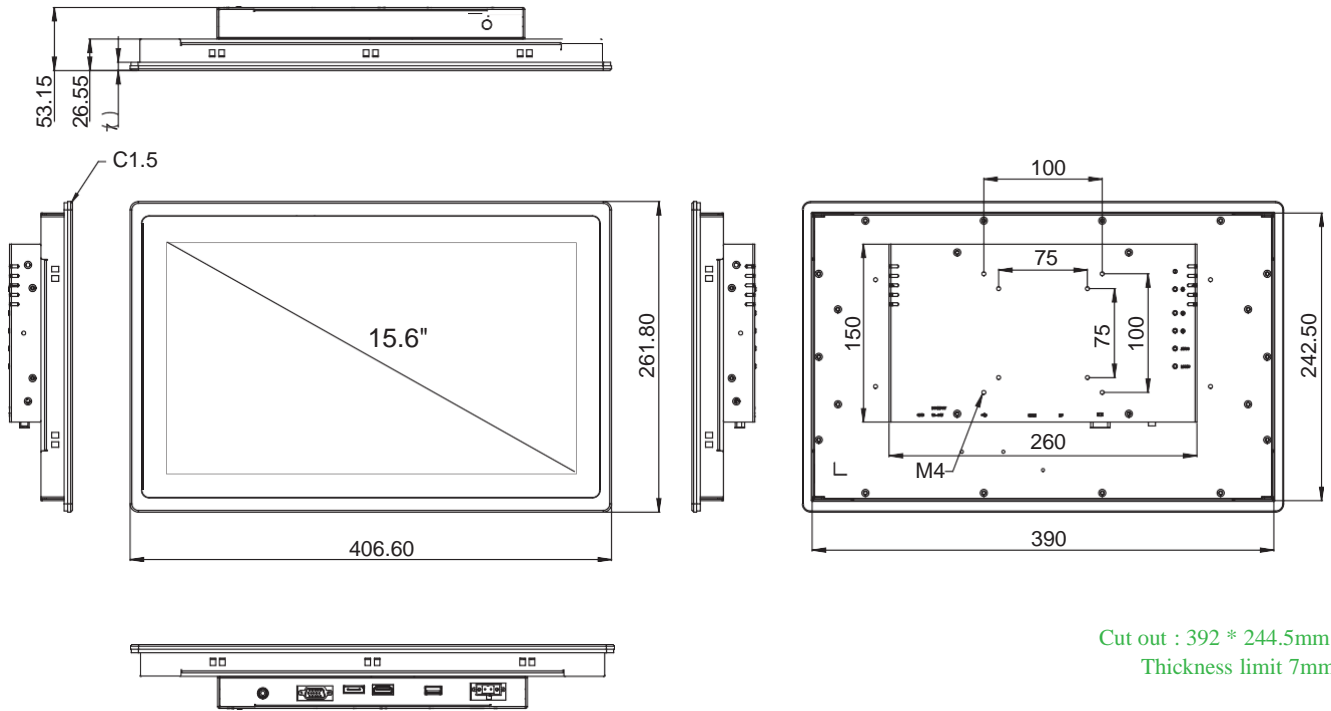

Cut out : 392 * 244.5mm
Thickness limit 7mm

→ Specifications

Model		TPM-3515RW-1A2	TPM-3515RW-2A2
Display	Panel Size	15.6" LCD Panel	
	Resolution	1366 x 768 (HD)	1920 x 1080 (FHD)
	Viewing Angle	80 x 80 (H), 80 x 80 (V)	85 x 85(H) x 85 x 85(V)
	Brightness	300 (cd/m ²)	450 (cd/m ²)
	Color Support	16.7 M	16.2 M
	Contrast Ratio	500:1	800:1
	Response Time	3 (msec)	12 (msec)
Touchscreen	Type	Resistive Touch screen	
	Surface Hardness	3 Mohs	
	Transparency	80% (±3%)	
I/O Interface	Video Interface	1 VGA, 1 DP, 1 HDMI	
	Touch Interface	1 USB	
OSD Control	Function Key	5 Keys: Menu, Up, Down, Auto Adjust, Monitor Power on/off	
Power	Power Connector	2-Pin Terminal Block	
	Power Input	12-24 V DC power input	
	Power Consumption (Typical)	1.22A @ 12V (14.7 W)	
	Power Adapter	50 W power adapter, with AC 100 ~ 240 V input and DC +12 V @ 4.17A MAX output	
Environment	Operating Temperature	-20~60° C (-4~140° F)	
	Storage Temperature	-40~90° C (-40~194° F)	
	Humidity	5~95% @ 40° C, Non-condensing	
	Vibration	5-500 Hz, 0.026 G ² /Hz, 2.16 Grms, X, Y, Z, 1 hour per axis	
	Certification	CE, FCC Class A	
General	Ingress Protection	IP65, Aluminum front Bezel	
	Dimensions (W x H x D)	406.6 x 261.8 x 53.15mm (16.01" x 10.31" x 2.09")	
	Weight	3.7kg (8.16lb)	
	Operating System	Windows XP, WES7-E, WES7-P, WE8S, Windows 7/8.1/10, ubuntu 14.04	