

VIO-219/PC100 series

19" SXGA Resistive / Capacitive Touch Thin Frame Panel PC with Intel® Celeron® Processor J1900, 4x COM



FEATURES

- 19" TFT SXGA 4:3 LCD with resistive 5-wire / projected capacitive touch
- Intel® Celeron® Processor J1900, 2.0 GHz
- 1x 204-pin DDR3L SODIMM. Max up to 8GB
- 1x 2.5" SATA HDD bay, 1x mSATA, 1x CFast, 2x SIM socket
- 2x full-size mini PCIe for communication or expansion modules
- 2x LAN, 1x VGA, 1x DisplayPort
- 6x RS-232/422/485 (w/ 2x internal), 1x USB 3.0, 3x USB 2.0, Audio
- 8x DI + 8x DO with isolation
- 9 to 50VDC wide range power input
- -10°C to 50°C extended operating temperature
- Designed with aluminum die-casting front frame
- IP65 compliant front panel / Fanless Industrial Display Computer
- Two 10W internal speakers built-in
- Multi-language OSD built-in

Display

LCD Size	19" [4:3]
Max. Resolution	1280 x 1024 [SXGA]
Brightness (cd/m ²)	350 / 1000 [Optional]
Contrast Ratio	1000:1
LCD Color	16.7M
Pixel Pitch (mm)	0.294 (H) x 0.294 (V)
Viewing Angle (H-V)	170 / 160
Backlight MTBF	50000 hrs (LED Backlight)

Touch

Resistive 5-wire	VIO-219R/PC100, VIO-219R/PC110
Projected Capacitive	VIO-219C/PC100, VIO-219C/PC110

System

Processor	Intel® Celeron® Processor J1900, Quad Core, 2MB Cache, 2.0 GHz
System Chipset	SoC Integrated
LAN Chipset	GbE1 & GbE2: Intel® I210-AT (Support Wake-on-LAN and PXE)
Audio Codec	Realtek ALC888S
System Memory	1x 204-Pin DDR3L 1066/1333MHz SODIMM. Max. up to 8 GB
BIOS	AMI 64Mbit SPI BIOS
Watchdog	Software Programmable Supports 1~255 sec. System Reset

Storage

SSD/HDD	1x External 2.5" SATA HDD Bay
mSATA	1x mSATA (Shared by 1x Mini PCIe)
CFast	1x CFast (Shared by 1x mSATA & 1x Mini PCIe)
SIM Socket	2x External SIM Socket

Expansion

Mini PCI Express	1x Full-size Mini PCIe Socket with USIM Socket (PCIe + USB + SATA) 1x Full-size Mini PCIe Socket with USIM Socket (PCIe + USB)
------------------	---

I/O

VGA	1x VGA
DisplayPort	1x DisplayPort
COM	4x RS-232/422/485 2x RS-232/422/485 (Internal)
USB	1x USB 3.0, 3x USB 2.0

LAN	2x RJ45
Audio	1x Mic-in, 1x Line-out
DIO	8 in / 8 out (Isolated)
Universal I/O Bracket	2x Universal I/O Bracket (By mini PCIe interface) (VIO-219/PC110 only)
Others	3x WiFi Antenna Holes 1x Power Switch, 1x AT/ATX Switch, 1x Remote Power On/Off

Other Features

Internal Speaker	AMP 10W + 10W
OSD	LCD On/Off, Auto, Menu, Up and Down Multi-language

Operating System

Windows	Windows 10
Linux	Linux kernel 3.X

Power

Power Mode	AT, ATX
Power Supply Voltage	9~50VDC
Power Ignition Sensing	Power Ignition Management
Power Connector	3-pin Terminal Block
Power Adaptor	Optional AC/DC 12V/5A, 60W
Power Protection	OVP (Over Voltage Protection) OCP (Over Current Protection) Reverse Protection

Environment

Operating Temp.	-10°C to 50°C
Storage Temp.	-20°C to 60°C
Relative Humidity	10% to 80% [non-condensing]
IP Level	IP 65 Compliant Front Panel
Vibration	With SSD: 1.5 Grms, 5 - 500 Hz, 0.5 hr/axis With HDD: 1 Grms, 5 - 500 Hz, 0.5 hr/axis
Shock	20G, half sine, 11ms
Standards / Certification	CE, FCC Class A

Physical

Front Panel Construction	Die-cast Flat Surface
Dimension	VIO-219/PC100: 450 (W) x 375 (D) x 71 (H) mm VIO-219/PC110: 450 (W) x 375 (D) x 93 (H) mm
Weight	7.18 ~ 7.26 kg
Mounting	VESA Mounting Holes 75 x 75mm, 100 x 100mm

EXTERNAL I/O MECHANICAL LAYOUT

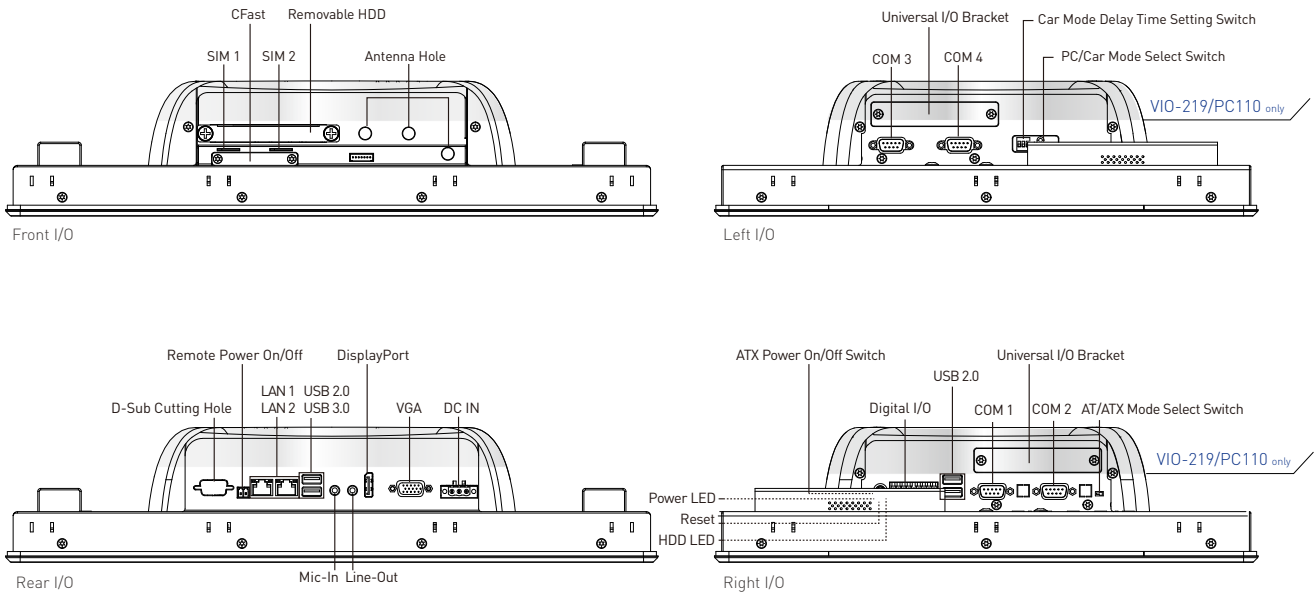

DIMENSION

Unit: mm

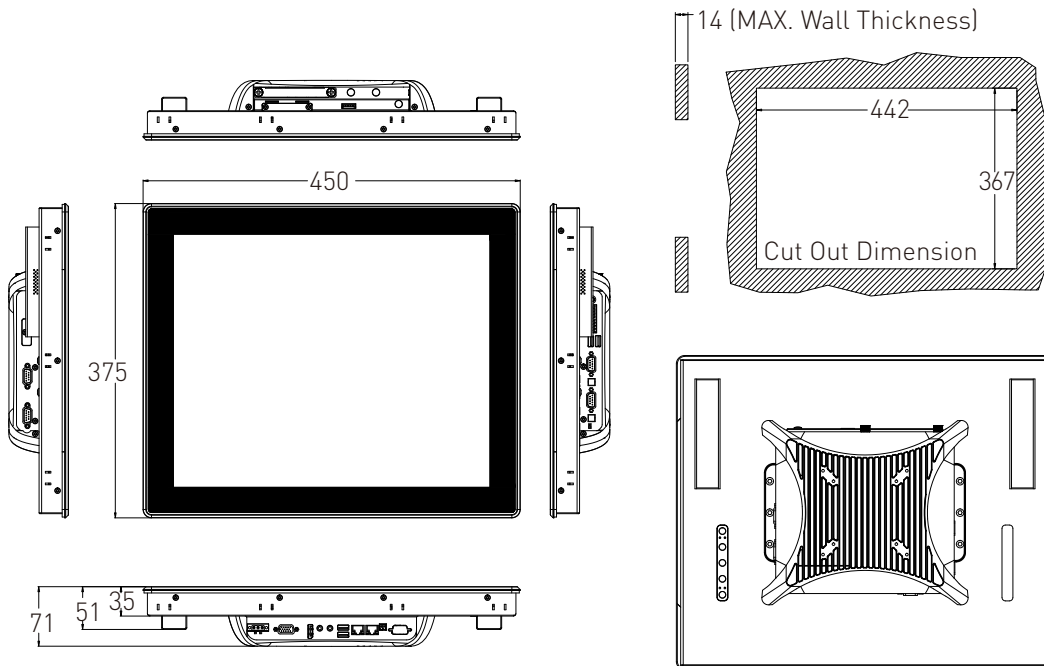

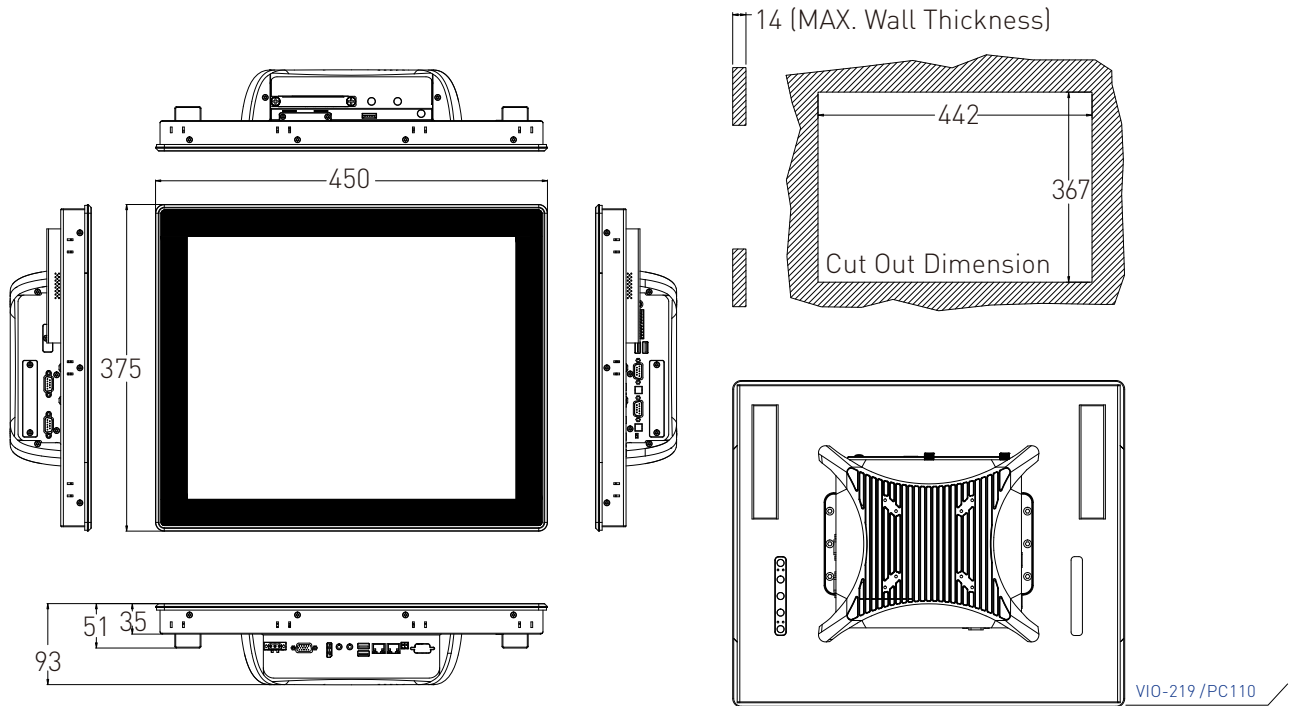

ORDERING INFORMATION

MODEL NO.	DESCRIPTION
1-E09A06008	Adapter AC/DC 12V 5A 60W with 3pin Terminal Block Plug 5.0mm Pitch
SFICBL022	Power Cord, 3-pin US Type, 180cm
1-TPCD00002	Power Cord, European Type
1-TPCD00001	Power Cord, 3-pin UK Type, 180cm

PACKING LIST

- 1x VIO-219/PC100 Series Panel PC
- 14x Panel Mount Kit
- 1x Utility DVD Driver
- 1x Screw Pack

AVAILABLE MODELS

MODEL NO.	DESCRIPTION
VIO-219R/PC100-J1900	19" SXGA Resistive Touch Thin Frame Panel PC with Intel® Celeron® Processor J1900, 4x COM
VIO-219C/PC100-J1900	19" SXGA Capacitive Touch Thin Frame Panel PC with Intel® Celeron® Processor J1900, 4x COM
VIO-219R/PC110-J1900	19" SXGA Resistive Touch Thin Frame Panel PC with Intel® Celeron® Processor J1900, 4x COM, 2x Universal I/O Bracket
VIO-219C/PC110-J1900	19" SXGA Capacitive Touch Thin Frame Panel PC with Intel® Celeron® Processor J1900, 4x COM, 2x Universal I/O Bracket